

2.0 PROJECT # 2: FIBER ATTENUATION

(Est. Time Required: 1:00 hr.)

In this exercise, one of the most important fiber parameters will be measured: attenuation per unit length of a multimode communications-grade optical fiber. Also discussed will be the way that the conditions under which light is launched into the fiber can affect this measurement. Finally, a brief introduction to mode scrambling will be made, and the student will be shown how to generate a desirable distribution of light in the fiber.

2.1 MEASUREMENT OF OPTICAL FIBER ATTENUATION

Section 0.4.1 contained a detailed description of the loss mechanisms in optical fibers. An expression for the amount of optical power which still remains in a fiber after it has propagated a distance, z , was given in Eq. 0-20 as

$$I(z) = I(0) 10^{-(\Gamma z/10)}. \quad (2-1)$$

The length of the fiber, z , is given in kilometers, and the attenuation coefficient, Γ , is given in decibels per kilometer (dB/km).

Because the designers of fiber optic systems need to know how much light will remain in a fiber after propagating a given distance, one of the most important specifications of an optical fiber is the fiber's attenuation. In principle, fiber attenuation is the easiest of all fiber measurements to make. The method which is generally used is called the "cutback method."¹ The general procedure to follow is a) launch light into a long length of fiber, b) measure the power at the far end of the fiber, c) cut off most of the fiber, leaving a short length at the input, and d) measure the power transmitted by the shorter length. The reason for leaving a short length of fiber at the input end of the system is to make sure that the loss that is measured is due solely to the loss of the fiber and not to the loss that occurs when the light source is coupled to the fiber. Fig. 2.1 shows a schematic illustration of the measurement system. (The mode scrambler shown in the figure was discussed in Section 0.3.2.)

The transmission through the fiber is written as

$$T = P_f / P_i, \quad (2-2)$$

where we have substituted P_i (initial power) and P_f (final power) for $I(0)$ and $I(z)$, respectively. A logarithmic result for the loss in decibels (dB), is given by

$$L \text{ (dB)} = -10 \log (P_f / P_i). \quad (2-3)$$

The minus sign causes the loss to be expressed as a positive number. This allows losses to be summed and then subtracted from an initial power when it is also expressed logarithmically. [In working with fiber optics, you will often find powers expressed in dBm, which means "dB with respect to 1 mW of optical power." Thus, e.g., 0 dBm = 1 mW, 3 dBm = 2 mW, and -10 dBm = 100 μ W. Note that when losses in dB are subtracted from powers in dBm, the result is in dBm. For example, an initial power of +3 dBm minus a loss of 3 dB results in a final power of 0 dBm. This is a shorthand way of saying "An initial power of 2 mW with 50% loss results in a final power of 1 mW."]

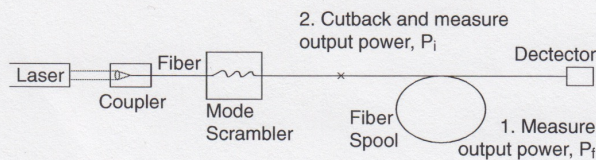

Figure 2.1. Schematic of laboratory set-up for cutback method of determining fiber attenuation.

The attenuation coefficient, Γ , in dB/km is found by dividing the loss, L , by the length of the fiber, z . The attenuation coefficient is then given by

$$\Gamma(\text{dB/km}) = (l / z) [-10 \log (P_f / P_i)]. \quad (2-4)$$

The total attenuation can then be found by multiplying the attenuation coefficient by the fiber length, giving a logarithmic result, in decibels (dB), for the fiber loss.

2.2 PRACTICAL PROBLEMS

The cutback method works well for high-loss fibers, with Γ on the order of 10 to 100 dB/km. However, meaningful measurements on low-loss fibers are more difficult. The highest quality fibers will have losses which are on the order of 1 dB/km or less, so that cutting a full 1 km from the fiber will result in a transmitted power decrease of less than 20%, putting greater demand on the measurement system's resolution and accuracy.

There is also an uncertainty due to the fact that the measured loss will depend on the characteristics of the way in which light is launched into the fiber. The launch conditions, which result in an overfilled or underfilled fiber, were discussed in **Section 0.3.2**. When a fiber is overfilled, many high-order and radiation modes are launched. These modes are more highly attenuated than are low-order modes. When a fiber is underfilled, mostly low-order modes are launched and lower losses occur.

The solution to this problem is to attempt to generate what is known as the stable mode distribution (also discussed in **Section 0.3.2**) as quickly as possible after launching. **Fig. 2.2** compares the transmission characteristics of the stable distribution with those of the overfilled and underfilled launch conditions. The stable mode distribution may be achieved, even in a short length of fiber, by using mode scrambling (**Section 0.3.2**) to induce coupling between the modes shortly after the light is launched.

Mode scrambling generates an approximation of a stable distribution immediately after launch and allows repeatable measurements (which approximate those that would be found in the field) to be made in the laboratory. **Fig. 2.2** compares the optical power in a fiber as a function of propagation distance for the three types of launch conditions: overfilled, underfilled, and stable distribution. The slope of the curve at large distances is equal to the attenuation coefficient.

It is the fact that the mode scrambling generates a stable distribution immediately after the source that allows a short cutback length to be used in the cutback method of measuring attenuation.

2.3 REFERENCE

1. D. Marcuse, Principles of Optical Fiber Measurements, Academic Press (New York) 1981, p. 226-236

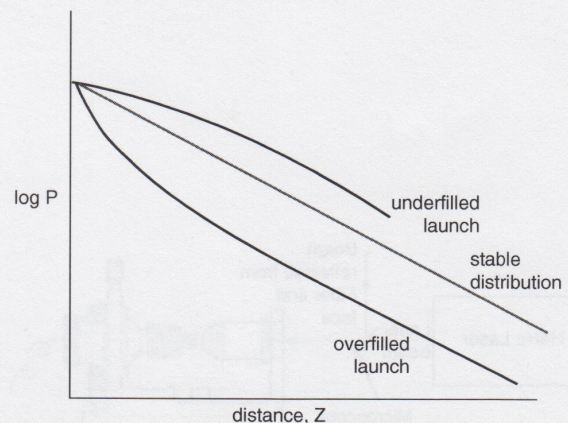

Figure 2.2. Comparison of attenuation characteristics of various launch conditions.

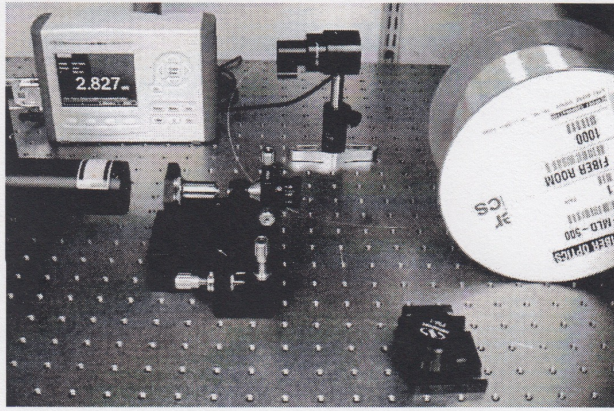

Figure 2.3. Laboratory set-up for determining fiber attenuation using the cutback method.

2.4 PARTS LIST

Cat#	Description	Qty.
F-MLD-500	100/140 μm Fiber, 500 m	1
R-30025	1.5 mW HeNe Laser	1
ULM-TILT	Laser Mount	1
340-RC	Rod Clamp	1
41	Short Rod	1
F-916	Fiber Coupler (without lens)	1
FPH-S	Fiber Chuck	1
M-20X	20X Objective Lens	1
F-CL1	Fiber Cleaver	1
FK-BLX	Allen Wrench Set	1
SK-25A	Screw Kit, $\frac{1}{4}$ -20	1
VPH-2	Post Holder, 2"	1
SPV-2	Post, 2"	1
1918-C	Power Meter	1
918D-SL-OD3	Low Power Detector, Silicon	1
818-FA2	Bare Fiber Holder Mount	1
FP3-FH1	Bare Fiber Holder	1
FM-1	Mode Scrambler	1
F-STR-175	Fiber Stripper	1
IMIC-1	Fiber Inspection Microscope	1

Additional equipment required: microscope slide cover glass.

2.5 INSTRUCTION SET

1. Prepare both ends of the 500 meter fiber spool which has been provided, as you learned to do in **Project #1 (Section 1.6.1, Steps 1-3)**. This fiber is the Newport F-MLD fiber with a 100 μm core and a 140 μm OD. You may have to use some care in freeing the end of the fiber, which was the start of the winding onto the spool. (This end will be referred to as the far end of the fiber.)

2. Thread the 818-FA2 onto the 918D-SL-OD3 Detector head and mount on a post. Place the cleaved far end of the fiber in the FP3-FH1 fiber holder so that 1 or 2 mm of fiber is sticking out the end, then insert the FP3-FH1 into the 818-FA2. There is no need to align the fiber to the detector since the FP3-FH1 and the 818-FA2 automatically align the fiber to the active area of the detector. The laboratory set-up for this project is shown in **Fig. 2.3**.

3. The use of the F-916 Fiber Coupler to couple light from a HeNe laser into a fiber is illustrated in **Fig. 2.4**. Align the coupler and the HeNe laser so that the laser beam is directed along the axis of the F-916 Fiber Coupler. Mount the M-20X microscope objective in the F-916. Place the cleaved front end of the fiber into the FPH-S and insert this into the coupler. Carefully align the fiber to maximize the light launched into the fiber, using the power meter to monitor the launched power. Place a microscope slide cover glass at 45° in the path of the laser beam to look at the Fresnel reflection from the fiber end face. Project the Fresnel reflection from the fiber end face onto a white screen. Focus the Fresnel reflected beam by adjusting the z component of the fiber position, as defined in **Fig. 2.4**; this is done by turning the z adjustment knob on the fiber positioner. When this reflection is focused, the fiber end face is in the focal plane of the coupler's microscope objective lens.

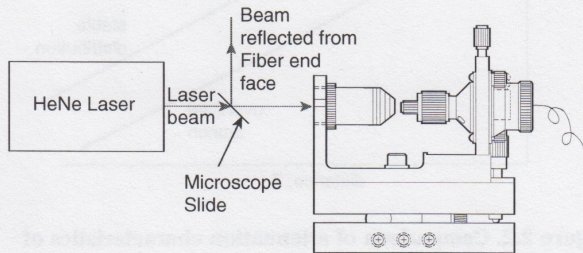

Figure 2.4. Coupling of HeNe laser light into a fiber using the F-916 Fiber Coupler.

4. Position the FM-1 Mode Scrambler at a convenient place near the launch end of the fiber, as shown in **Fig. 2.3**.

5. Rotate the knob of the FM-1 counter-clockwise to fully separate the two corrugated surfaces. The FM-1 Mode Scrambler is illustrated in **Fig. 2.5**. Place the fiber between the two corrugated surfaces of the Mode Scrambler. Leave the fiber jacket on to protect the fragile glass fiber. Rotate the knob clockwise until the corrugated surfaces just contact the fiber. Examine the far-field distribution of the output of the fiber. Rotate the knob further clockwise and notice the changes in the distribution as the amount of bending of the fiber is changed. Since a narrow, collimated HeNe beam is being used to launch light into the fiber, the original launched distribution will be underfilled. When the distribution of the output just fills the NA of the fiber, an approximation of the stable distribution has been achieved. This can be determined by projecting the output of the fiber onto a white screen. The diameter of the output distribution will change as the knob of the FM-1 is rotated clockwise and counterclockwise. The knob should be rotated to a position such that the diameter of the output distribution is just about to increase. (Obviously this will involve observing the diameter increasing, and then reversing the direction of the knob slightly.) An approximation of a stable distribution has now been achieved. It is important that no more bending be added than is necessary to accomplish this, as this will result in excess loss. This launching and mode-scrambling set-up should not be changed again during the remainder of the exercise.

6. Measure the power out of the far end of the fiber. Note the exact length of the fiber. It will be part of the information on the label of the spool.

7. Break off the fiber ~2 meters after the mode scrambler (see **Fig. 2.1**) from the launching set-up. (Be sure to note on the spool how much fiber you have removed, so that other people using the same spool in the future will be able to obtain accurate results.) Cleave the broken end of the fiber and measure the output from the cutback segment.

8. Calculate the fiber attenuation, using Eq. 2-4, and compare this with the attenuation written in the fiber specification on the spool. Your value is probably somewhat higher than the specification. Why? (**HINT:** Go back and look at **Fig. 0.25**.)

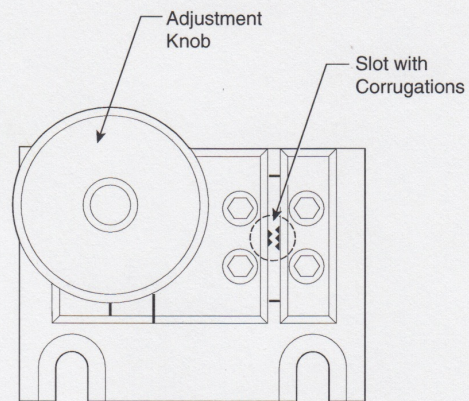

Figure 2.5. Model FM-1 Mode Scrambler.